

Features:

- Hybrid Integrated Circuit
- Surface Mounted Device Type
- Shield Case : Nickel Silver
- 18PIN Type





 ELECTROSTATIC SENSITIVE DEVICE
 OBSERVE HANDLING PRECAUTIONS

Electrical Specifications (TA=+25Deg.C, 50Ω system)

NO	ITEM	UNIT	MIN	TYP	MAX
1	Operating Frequency Range	MHz	666.5	676.5	686.5
2	Output Power Level	dBm	+1.0	+3.0	+5.0
3	Harmonics Level (2 nd)	dBc			-20
4	Spurious Level	dBc			-70
5	Phase Noise at offset @ 1kHz at offset @ 10kHz at offset @ 100kHz	dBc/Hz dBc/Hz dBc/Hz		-82 -108 -120	
6	Lock Time	msec			30
7	Output Impedance	Ω		50	
8	VCO Supply Voltage	V	+4.75	+5.00	+5.25
9	PLL Supply Voltage	V	+4.75	+5.00	+5.25
10	Reference Freq.	MHz		10	
11	Reference Freq. Level	dBm	+0.0		
12	Ch Step.	kHz		25	
13	Current Consumption	mA			40
14	Lock Detector Voltage	V Low	V		+0.5
		V High	V	+4.5	
15	Operating Temp. Range	°C	-30		+75

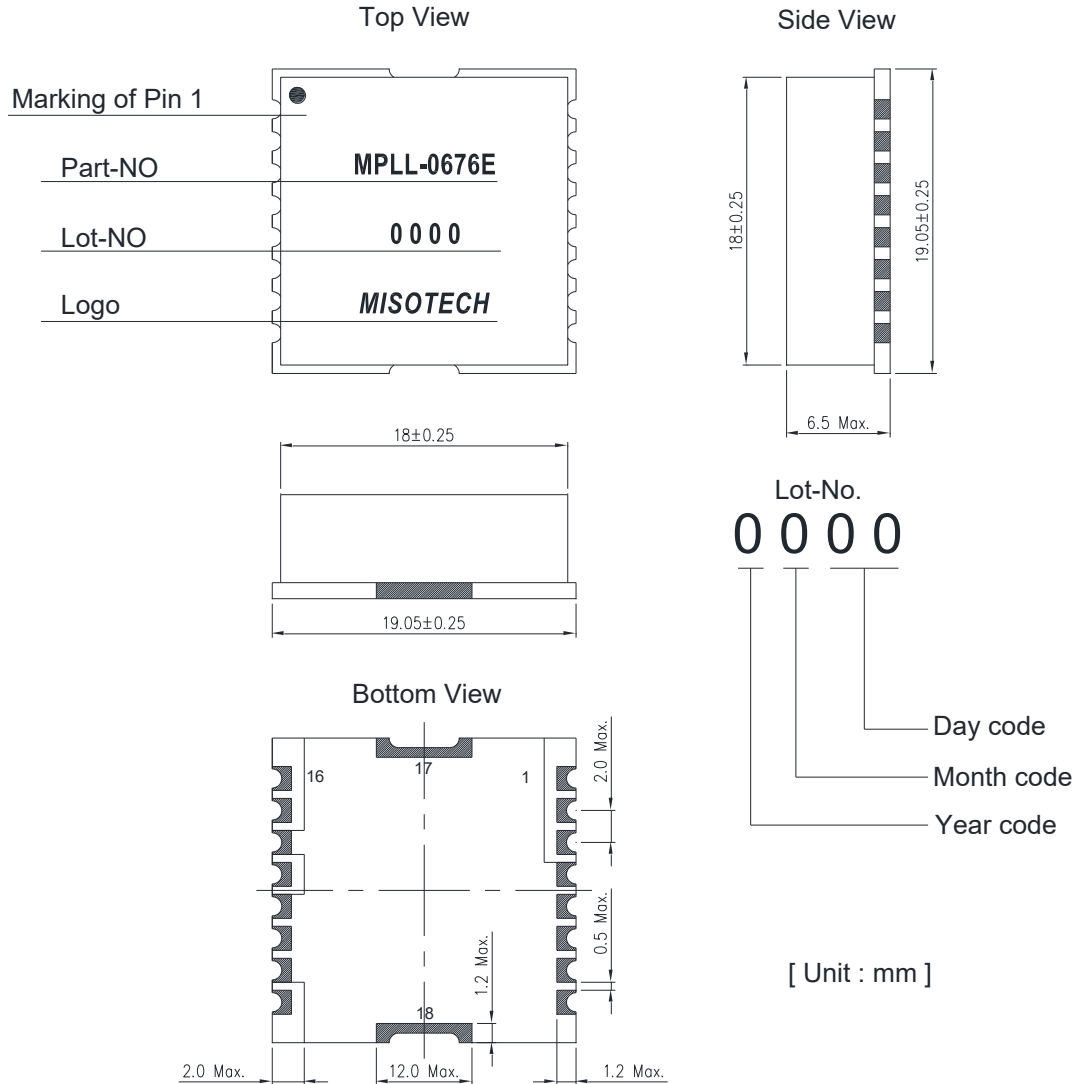
Dimensions



Terminal Connection			
Pin NO	Terminal NAME	Pin NO	Terminal NAME
1	Clock (CLK)	9	VCO Vcc
2	Data	13	RF Out
3	Enable (LE)	15	PLL Vcc
4	Ref. IN	16	Lock Detect (LD)
All Other Pins are Ground			

Packing

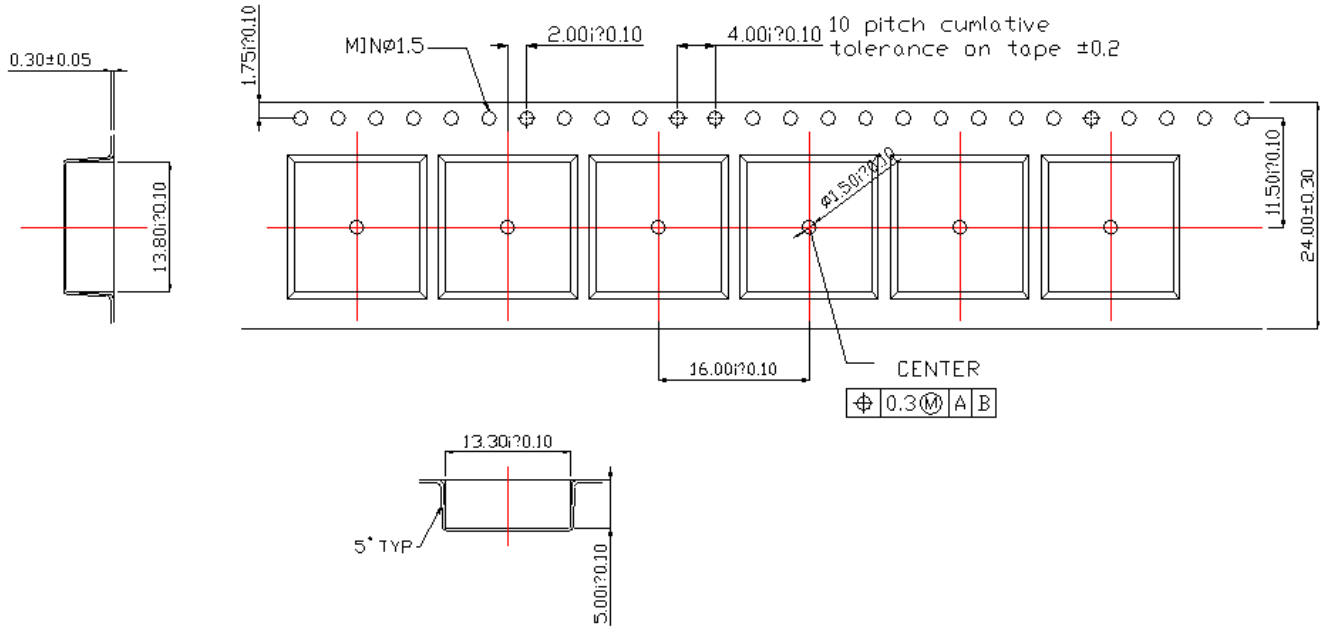

Taping

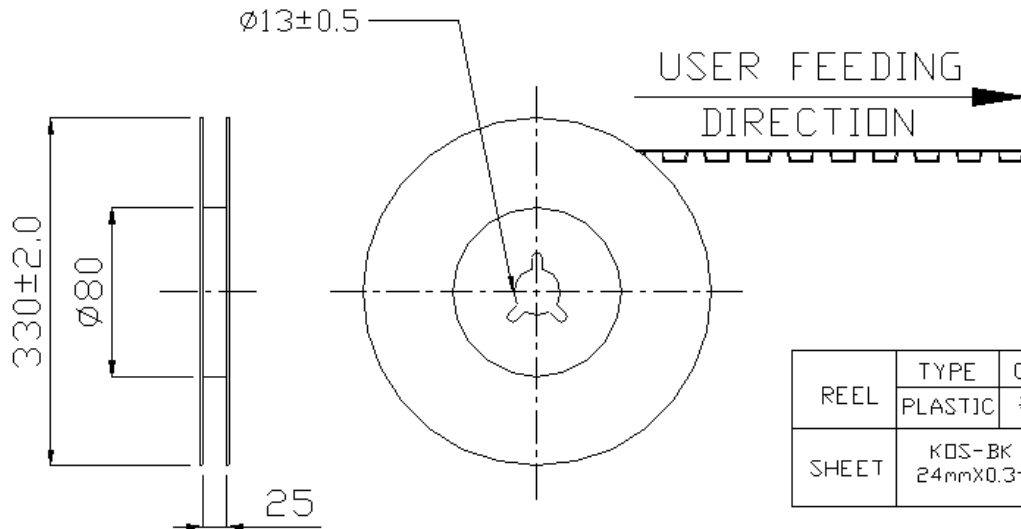

REEL	TYPE	COLOR	HUB	SIZE
	PLASTIC	흑,백색	80	330
SHEET	KDS-BK 24mmX0.3t	POCKET COUNTER	750 POCKET	

REEL DIMENSION

Reel